

Date	Group	No.	Page
1.2007	221	50	1(13)

Oil Pump Replacement D13F

Oil Pump, Replacement

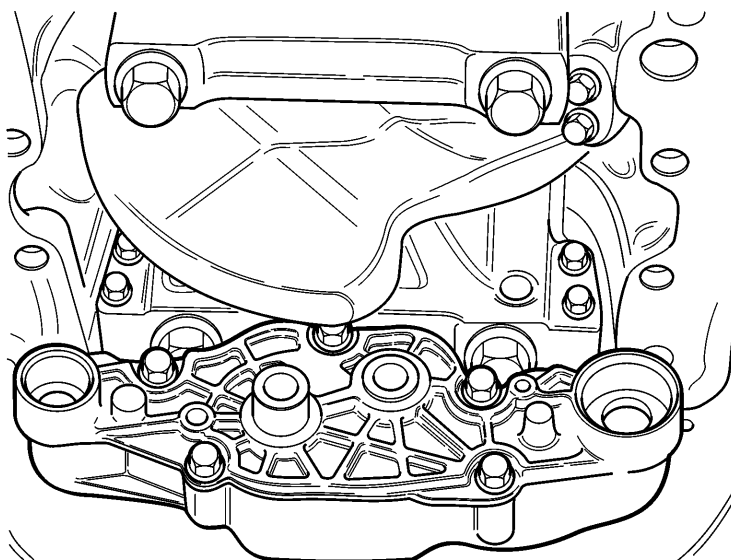

T2022249

Contents

- "Special Tools" page 2
- "Oil Pump, Replacement" page 3

Note: Information is subject to change without notice. Illustrations are used for reference only and can differ slightly from the actual vehicle being serviced. However, key components addressed in this information are represented as accurately as possible.

Tools

Special Tools

For special tools ordering instructions, refer to Tools Information, group 08.

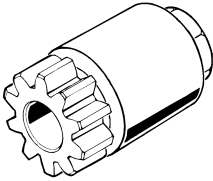

T0012612

88800014

Flywheel Turning Tool

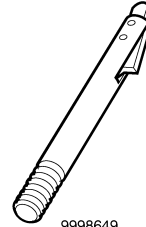

9998649

W2006137

9998649

Stiffening Frame Tool

Service Procedures

2211-03-02-01

Oil Pump, Replacement

You must read and understand the precautions and guidelines in Service Information, group 20, "General Safety Practices, Engine" before performing this procedure. If you are not properly trained and certified in this procedure, ask your supervisor for training before you perform it.

Special tools: 88800014, 9998649

Removal

1

Apply the parking brake and place the shift lever in neutral.

2

Remove all cables from ground (negative) battery terminals to prevent personal injury from electrical shock.

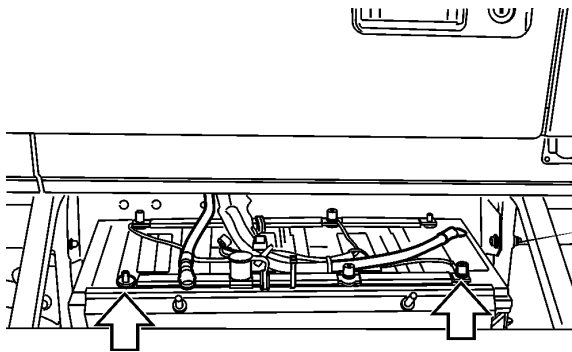

W2003815

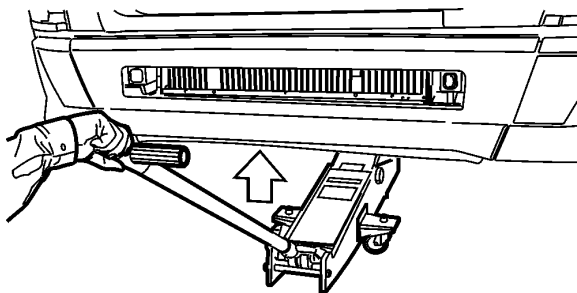

W2003873

3

Using a hydraulic jack, lift the front axle until the front wheels are off the ground. Position jackstands of a suitable capacity under the frame in a position which will allow the front axle to hang free.

4

If required, remove the skid plate to allow access for oil pan removal.

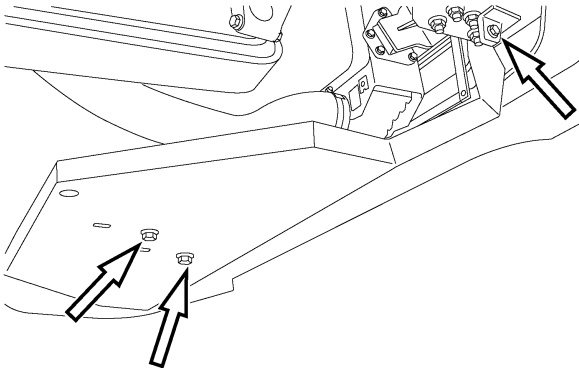

W2006077

5

Place an approved container under the oil pan. Drain the oil by removing the drain plug.

Note: Use only hand tools when removing and installing the drain plug. Do not use an air ratchet or similar air tool.

6

Remove the transmission cooler line bracket nuts and separate the brackets from the oil pan fasteners. Position the cooler lines out of the way.

Note: Mark the transmission oil cooler bracket stud locations to aid in reassembly.

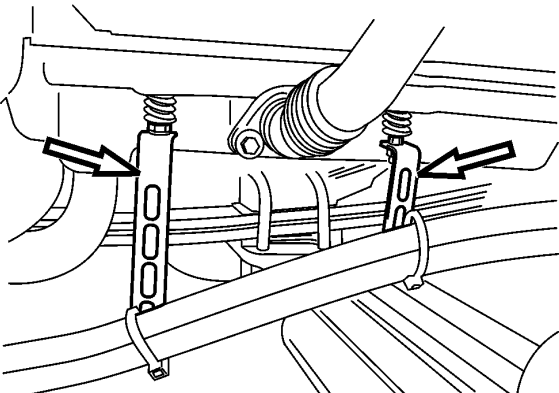

W2004874

7

Pull the dipstick partially out of the dipstick tube. Remove the dipstick tube fastener and tube from the oil pan. Remove and discard the O-ring.

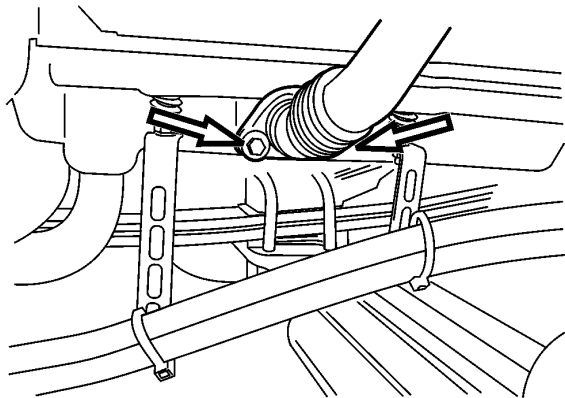

W2004884

8
Remove the oil fill tube fasteners and tube from the oil pan. Remove and discard the tube O-ring.

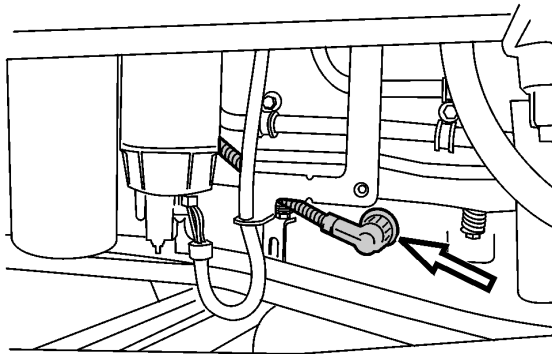

W2004876

9
Disconnect the oil level/temperature sensor connector.

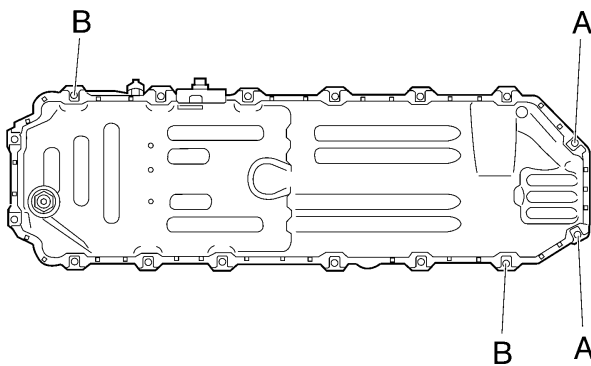

W2005226

10
Remove the two bolts marked A. Loosen the two bolts marked B, but do not remove. Remove all the other bolts.

11
With assistance, remove the two remaining bolts (B) and carefully lower and remove the oil pan.

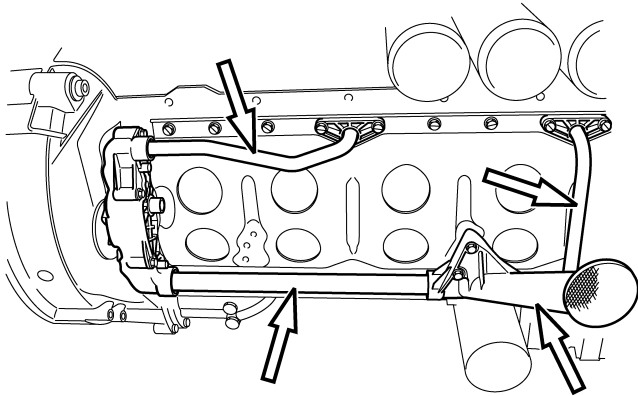

W2006100

12

- Loosen and remove the bolts securing the oil strainer to the engine stiffening frame. Remove the oil strainer and pickup (suction) tube. Slide the tube out of the oil pump.
- Remove the fasteners securing the oil pressure crossover pipe to the skirt of the cylinder block. Remove the pipe.
- Remove the fasteners securing the oil pressure pipe to the skirt of the cylinder block. Slide the pipe out of the oil pump.

13

Remove the engine stiffening frame.

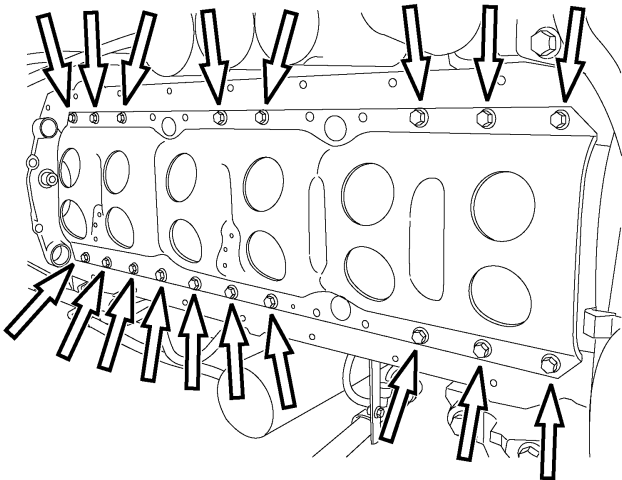

W2006101



CAUTION

The engine stiffening frame has sharp edges which can cause injury. Wear protective gloves when handling.

14

If needed, remove the plug from the flywheel housing and install the flywheel turning tool.

88800014

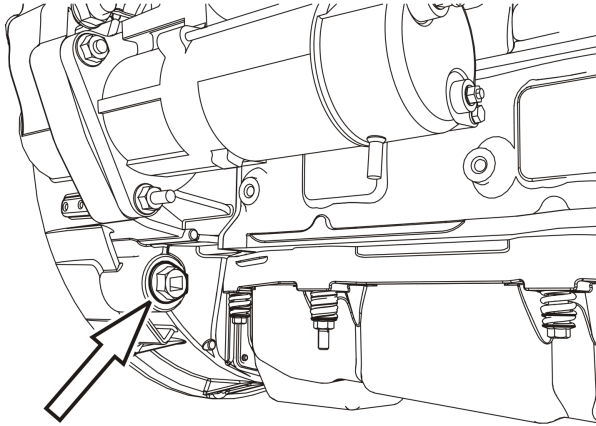

W0002368

15

If needed, rotate the crankshaft using the flywheel turning tool to move the crankshaft out of the way.

88800014

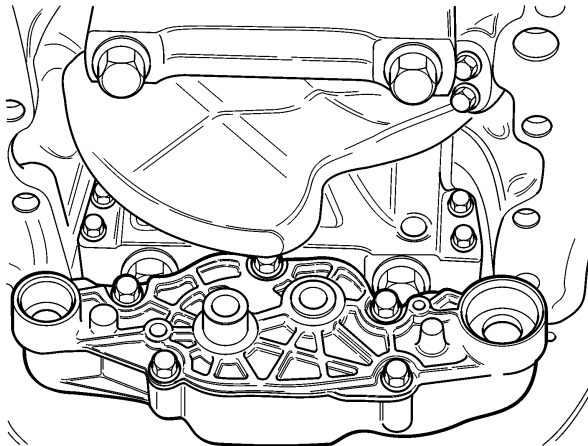

T2022249

16

Remove the bolts securing the oil pump to the crankshaft rear main bearing cap and remove the pump.

Installation

Note: Clean the oil pump mounting surface of the rear main bearing cap before installing the new oil pump.

1

Position the oil pump to the rear main bearing cap, install the bolts and torque-tighten to specification.

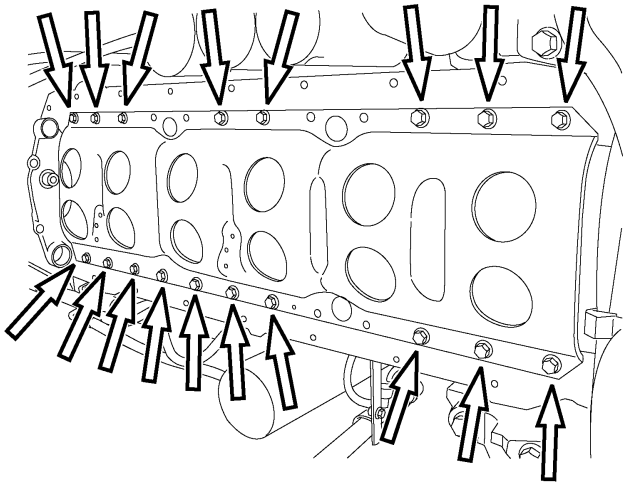

W2006101

- 2**
Install the engine stiffening frame, new bolts and torque-tighten to specification.

CAUTION

The engine stiffening frame has sharp edges which can cause injury. Wear protective gloves when handling.

Note: The available tool 9998649 can be used to hold stiffening frame in position while fasteners are started.

Note: The engine stiffening frame attaching bolts are a ONE TIME USE ONLY. New bolts must be installed.

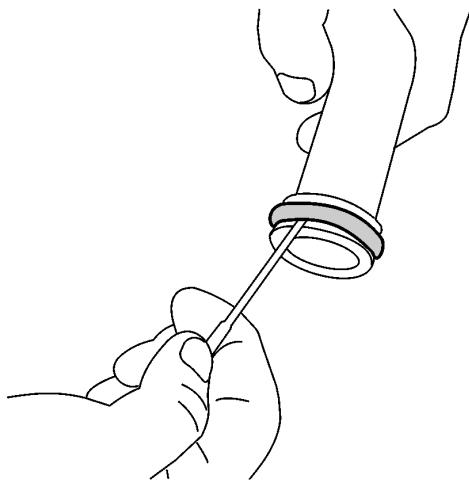

W2004956

- 3**
Replace the O-rings of the oil pressure pipe, oil suction pipe and oil crossover pipe. Lubricate the O-rings with engine oil before installation.

Note: Separate the oil suction pipe from the oil strainer as needed to replace that O-ring. Clean and inspect the oil strainer, suction pipe, crossover pipe and pressure pipe for cracks. Replace if necessary.

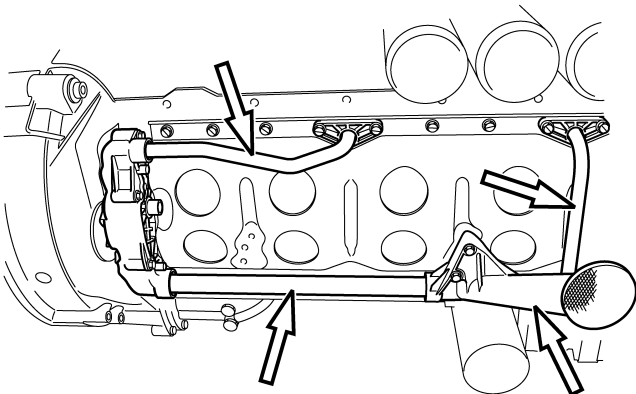

W2006100

- 4**
- Slide the oil pressure pipe into the oil pump, position the pipe flange to the cylinder block, install the fasteners and torque-tighten to specification.
 - Position the oil pressure crossover pipe to the skirts of the cylinder block, install the fasteners and torque-tighten to specification.
 - Assemble the oil strainer and oil pickup pipe. Slide the oil pickup pipe into the oil pump, position the oil strainer to the engine stiffening frame, install the fasteners and torque-tighten to specification.

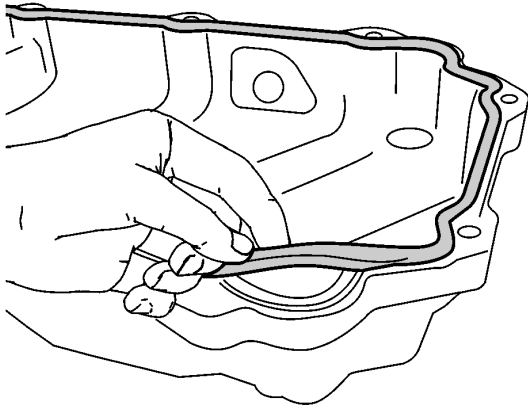

W2004878

5
Remove the rubber gasket from the oil pan. Clean the oil pan and contact surface on the cylinder block, flywheel housing and front seal cover. All surfaces must be completely free of any grease or oil residue.

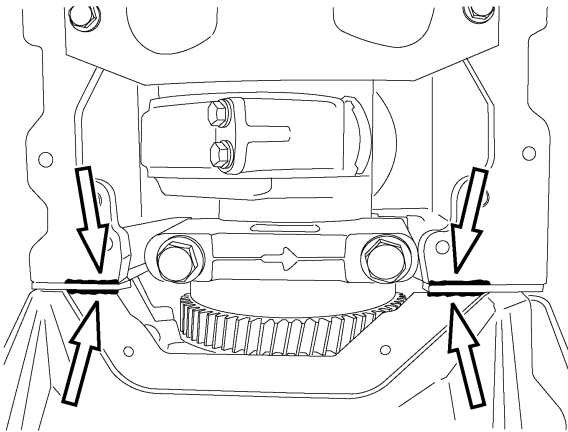

W2006078

6
Apply a two mm (0.079 inch) bead of Volvo sealant to the seams between the flywheel housing and the timing gear mounting plate and between the timing gear mounting plate and the cylinder block.

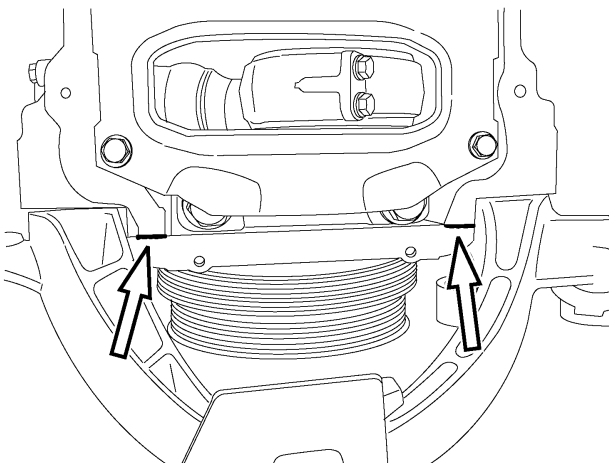

W2006079

7
Apply a two mm (0.079 inch) bead of Volvo sealant to the seam between the front seal cover and the cylinder block.

- 8**
Position a new rubber gasket on the oil pan.

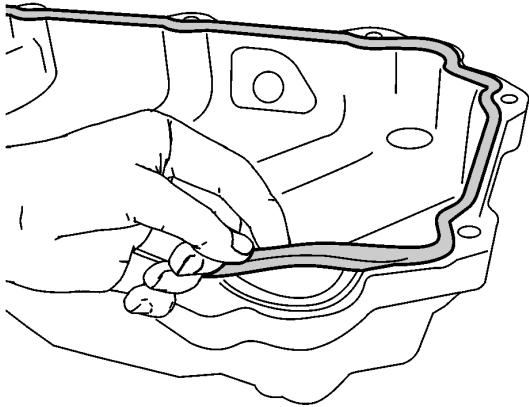

W2004878

- 9**
With assistance, position the oil pan to the engine block and install the two bolts marked A and B. Torque-tighten bolts to 24 ± 4 Nm (18 ± 3 ft-lb).

Note: Use care to avoid damaging the oil pickup.

Note: Install transmission oil cooler bracket studs in locations marked previously.

24 ± 4 Nm
(18 ± 3 ft-lb)

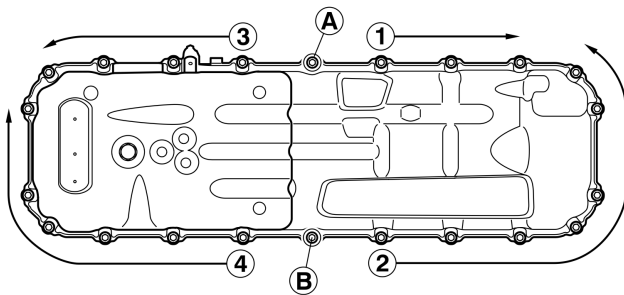

T2023838

- 10**
Tighten the bolts from the middle and outwards in order 1–4 as shown. Torque-tighten the bolts to 24 ± 4 Nm (18 ± 3 ft-lb). Finish by checking the torque for bolts A and B.

24 ± 4 Nm
(18 ± 3 ft-lb)

- 11**
Install the oil drain plug and torque-tighten to specification.

Note: The drain plug must not be installed with a copper washer. Always use the steel washer.

Note: Do not use an air impact ratchet or similar air tool to remove or install the oil drain plug.

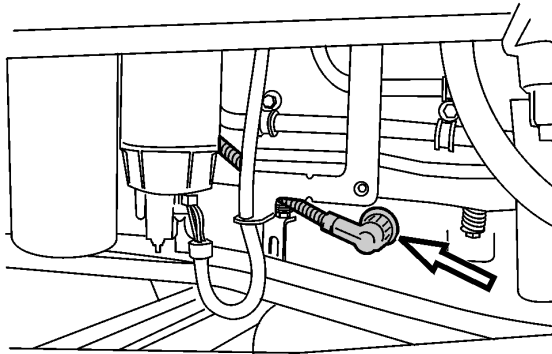

W2004876

12
Plug in the oil level/temperature sensor connector.

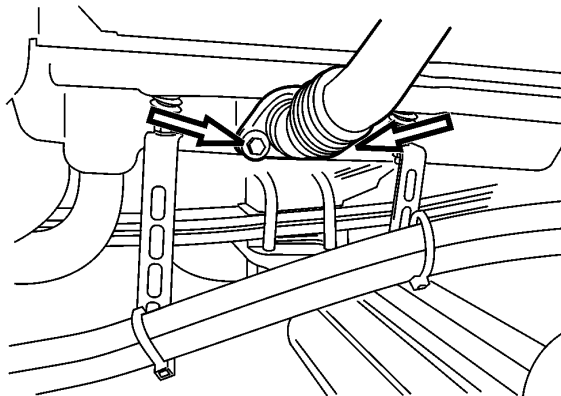

W2004884

13
Install a new fill tube O-ring and position the fill tube onto the side of the oil pan. Install the oil fill tube fasteners and tighten to secure.

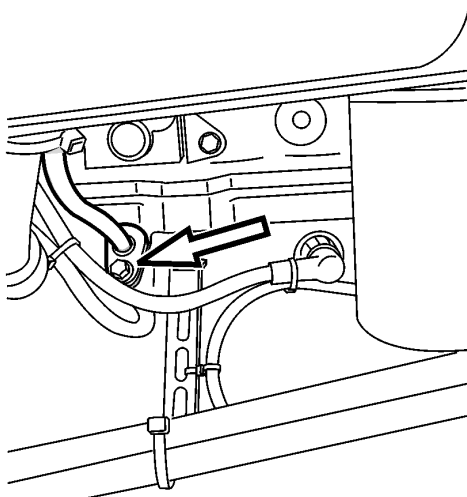

W2005086

14
Install a new O-ring on the dipstick tube, then install the dipstick tube and secure with the fastener. Install the dipstick.

- 15**
Position the transmission oil cooler line brackets onto the oil pan fastener stud locations. Install the cooler line bracket nuts and tighten to secure.

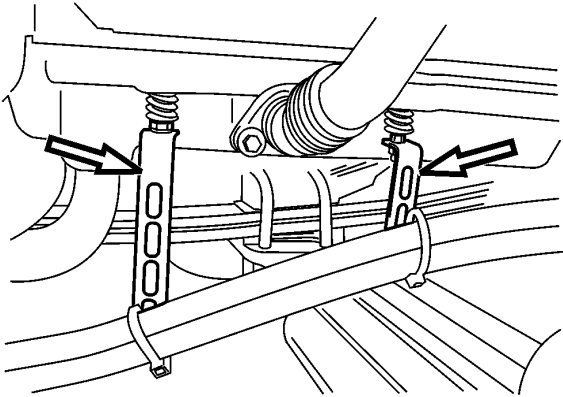

W2004874

- 16**
Install skid plate if removed for access.

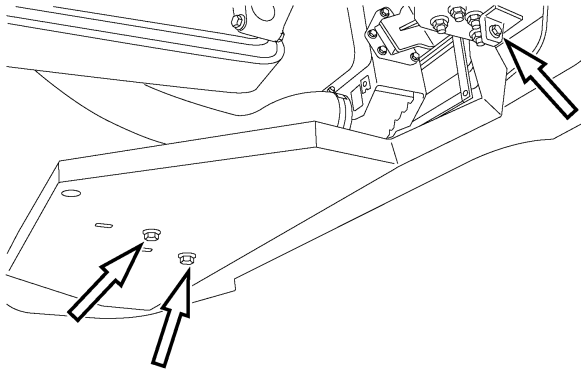

W2006077

- 17**
Using a hydraulic jack, raise the front axle and remove the jackstands from under the frame. Lower the front axle and remove the hydraulic jack.

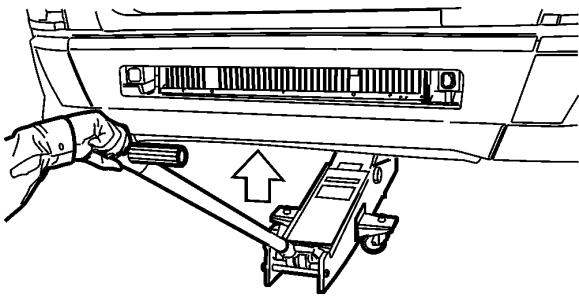

W2003873

- 18**
Fill the engine with approved oil to the full level on the dipstick.

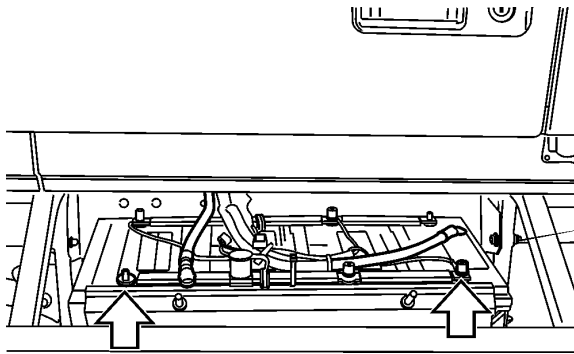

W2003815

19

Install all previously removed cables to the ground (negative) battery terminals.

20

Start the engine, check for leaks and proper operation. After shutdown, replenish fluids as necessary.