

Fuel System Specifications D13F

Fuel System, Specifications

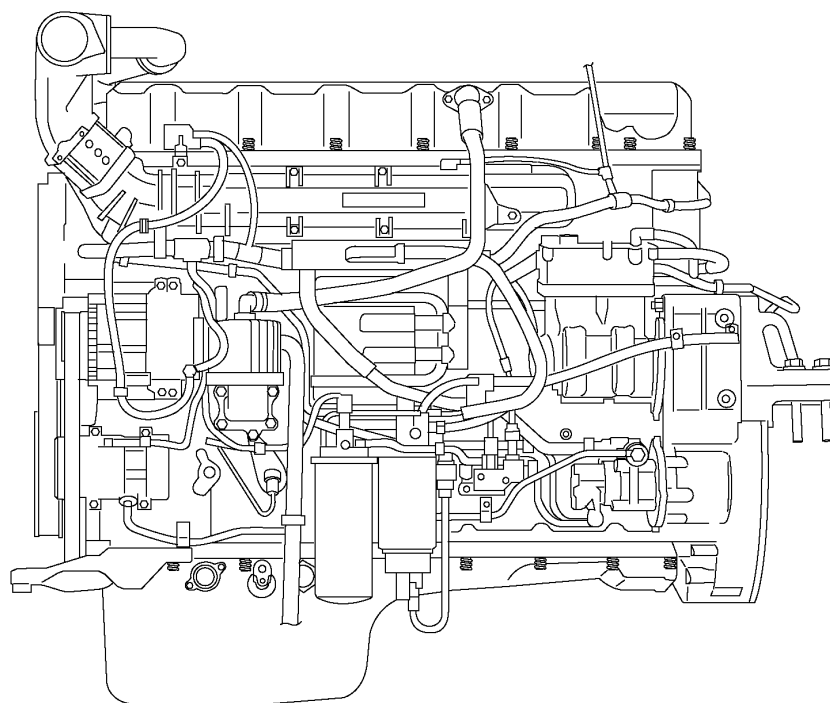

W2005843

This information provides specifications for the fuel system on the Volvo D13F engine.

For other engine specifications, refer to Service Information, group 20.

Contents

- "Fuel System" page 2

Note: Information is subject to change without notice. Illustrations are used for reference only and can differ slightly from the actual vehicle being serviced. However, key components addressed in this information are represented as accurately as possible.

Specifications

Fuel System

Fuel Supply Pressure

Fuel Pump

Fuel pressure at:	
600 rpm	100 kPa (14.5 psi) minimum
1200 rpm	300 kPa (43.5 psi) minimum
Full load	300 kPa (43.5 psi) minimum

Overflow Valve

Opening pressure	300–550 kPa (43.5–80 psi)
------------------	---------------------------

Tightening Torques

Injector hold down, unit injector (<i>new copper sleeve</i>)	
This tightening procedure only applies when a new copper sleeve is installed, where the first tightening “seats” the copper sleeve.	
First tightening	
Step 1	20 +5/–0 Nm (15 +4/–0 ft-lb)
Step 2	180 ± 5 degrees angle of tightening
Loosen the Injector hold down screw before the second tightening.	
Second tightening	
Step 1	20 +5/–0 Nm (15 +4/–0 ft-lb)
Step 2	60 ± 5 degrees angle of tightening
Injector hold down, unit injector (<i>reusing copper sleeve</i>)	
Step 1	20 +5/–0 Nm (15 +4/–0 ft-lb)
Step 2	60 ± 5 degrees angle of tightening
Locknut for adjusting bolt, unit injector	52 ± 4 Nm (38 ± 3 ft-lb)
or angle tighten, after contact	45 ± 5 degrees
Fuel pump	8 +2/–0 Nm (6 +1.5/–0 ft-lb)
Tandem pump	24 ± 4 Nm (18 ± 3 ft-lb)
Fuel passage plug in cylinder head	30 ± 3 Nm (22 ± 2 ft-lb)
Fuel filter (pre, main)	18 ± 3 Nm (13 ± 2 ft-lb)
Fuel filter housing	24 ± 4 Nm (18 ± 3 ft-lb)
Fuel pressure sensor	25 ± 3 Nm (18.5 ± 2 ft-lb)
Aftertreatment fuel injector, fuel supply line	15 ± 0.5 Nm (135 ± 5 in-lb)

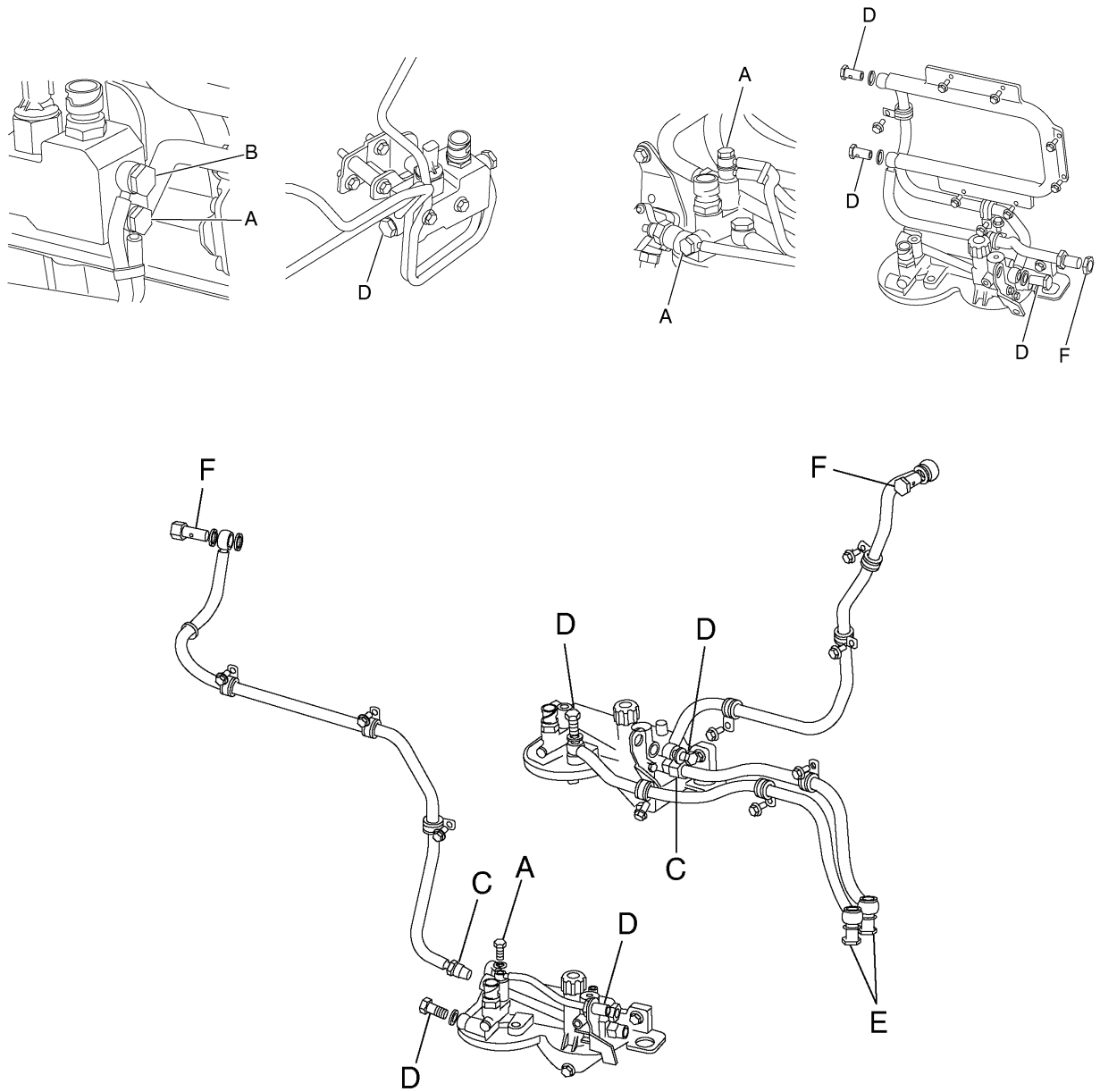

Fuel line fittings:

A	18 ± 3 Nm (13 ± 2 ft-lb)
B	28 ± 4 Nm (20.5 ± 3 ft-lb)
C	30 ± 4 Nm (22 ± 3 ft-lb)
D	35 ± 5 Nm (26 ± 4 ft-lb)
E	40 ± 5 Nm (29.5 ± 4 ft-lb)
F	48 ± 5 Nm (35 ± 4 ft-lb)