

This Service Bulletin replaces SB 216-39, "Flywheel Ring Gear, Replacement" dated 4.2007, publication no. PV776-20180020.

Date	Group	No.	Page
11.2007	216	39	1(3)

Flywheel Ring Gear, Replacement D11F, D13F, D16F

Flywheel Ring Gear, Replacement

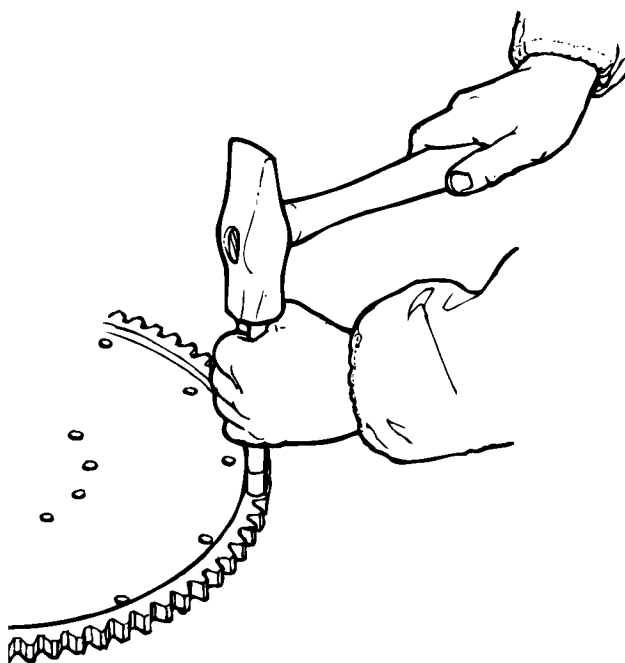

T2006661

Contents

- "Flywheel Ring Gear, Replacement" page 2

Note: Information is subject to change without notice. Illustrations are used for reference only and may differ slightly from the actual vehicle being serviced. However, key components addressed in this information are represented as accurately as possible.

2166-03-05-01 Flywheel Ring Gear, Replacement Flywheel removed

You must read and understand the precautions and guidelines in Service Information, group 20, "General Safety Practices, Engine" before performing this procedure. If you are not properly trained and certified in this procedure, ask your supervisor for training before you perform it.

Removal

1

Heat the starter ring in four equally spaced locations on the outer edge. This will expand the ring to allow for removal from the flywheel.

Note: To avoid burns, use caution when handling the starter ring (ring will be very hot).

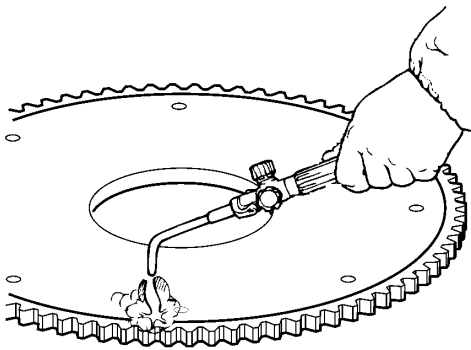

W2006247

2



WARNING

To prevent personal injury, use proper protection when removing the ring from the flywheel.

Once the ring has been heated, use a hammer and punch to tap the ring free from the flywheel.

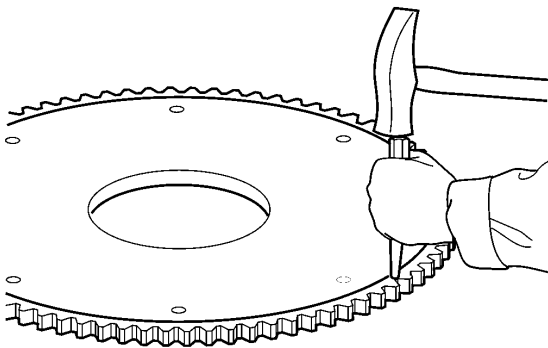

W2006248

Installation

3

Heat replacement ring. Using a soft face hammer, drive the ring onto the flywheel until it is laying flat on flywheel.

Note: To avoid burns, use caution when handling the starter ring (ring will be very hot)

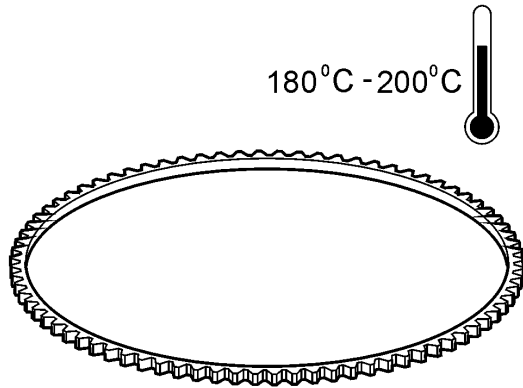

T2020600

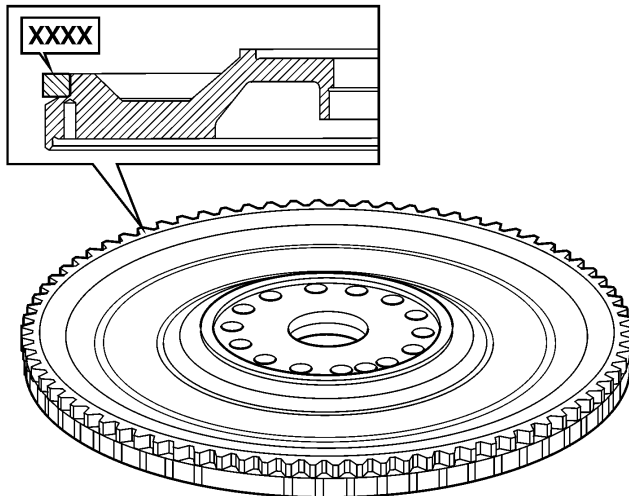

T2022203

4

The markings on the flywheel ring gear must face outwards from the engine.