

This Service Bulletin replaces SB 258-0803, "Emission Label, Clean Idle" dated 06.2008, publication number PV776-20158511.

Date	Group	No.	Page
10.2008	258	08	1(4)

Emission Label, Clean Idle

Emission Label, Clean Idle

The California Air Resources Board (CARB) has enacted regulations to limit idle time of heavy-duty trucks to reduce emissions of oxides of nitrogen (NOx), one of the main pollutants in diesel exhaust.

California has adopted idling requirements on 2008 model year engines. To be "California Certified", the vehicles with 2008 model year engines must include either:

1. A tamper proof shut-off device which will limit the maximum engine idling to five minutes.
2. Be certified to meet the very low limit of 30 grams/hour NOx during engine idling. An official "Certified Clean Idle" holographic decal must be displayed on the hood of any truck equipped with a low NOx at idle certified engine.

California certified engines will be identified by a Certified Clean Idle emission label on the engine. If the engine is not California-certified, it will be EPA-certified, and display an EPA emission label on the engine. Other states have adopted and/or planning to adopt this regulation.



W2006508

Note: Serialized Holographic Hood Decal Engines that have California certified engines with 2008 clean idle technology must include this serialized holographic hood decal and may be idled longer than 5 minutes, where legal and if necessary.

Volvo has created an option to meet the California Certified Clean Idle requirement of 30 grams/hour NOx at idle for all trucks in the required states. Modifications include software changes to the EECU to change from an EPA engine to a California certified engine. With these changes, the engines can be certified to meet the stringent 30g/hr NOx idling requirement. The regulation is based on the date the ENGINE is built, not the model year or build date of the VEHICLE. Engines built with 2007 emissions can be upgraded to meet the standard. The regulation becomes mandatory with engines built on or after January 1, 2008.

At this time California certified engines are allowed to be changed from EPA emissions to California certified engines.

Location of Certified Clean Idle label The certified clean idle hood label must be installed in the proper location. Before installing a label verify that the engine emission label meets the California certified certification.

Labels may only be installed on vehicles that are California certified engines. It is the Volvo dealerships responsibility to properly install aftermarket upgraded labels. The label is attached to the driver's side of the hood within the specifications listed below.

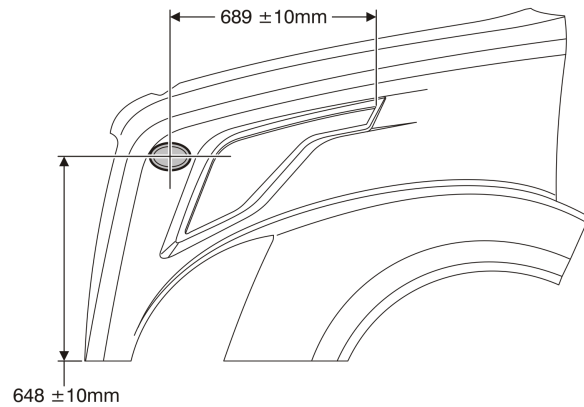

W2006509

VNL Hood

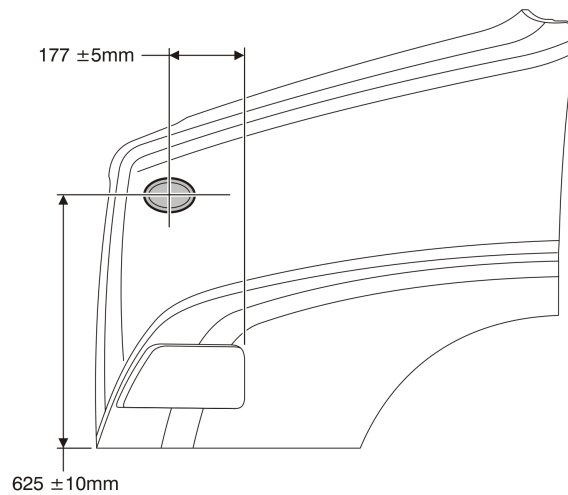

W2006510

VNM Hood

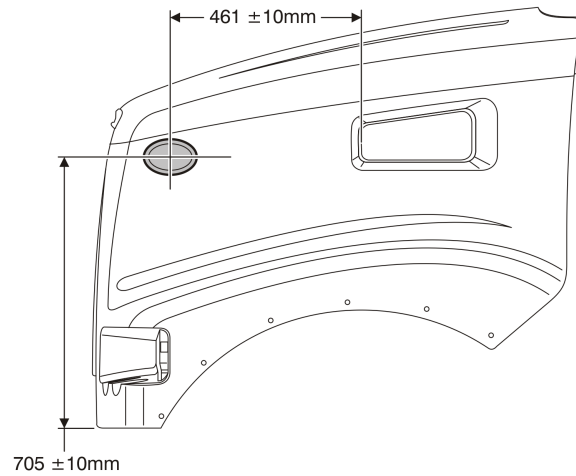

W2006511

VHD Hood

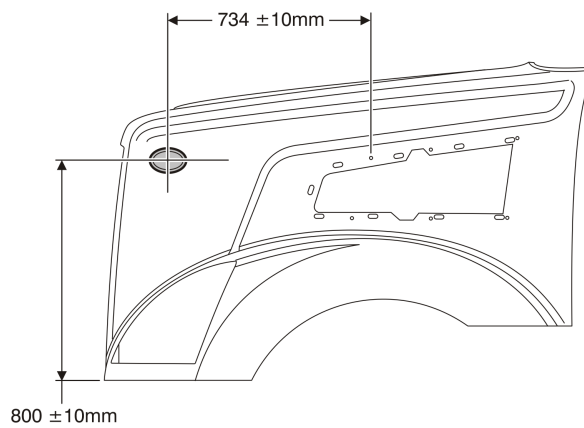

W2006512

VT Hood

The certified clean idle hood label location provision shown above can be impractical or infeasible. There is the possibility of situations such as side mirror mounts or configurations that prevent adequate or ideal label installation to the hood. In such a case the label may be affixed in a different location. The alternative location will be on the left (driver's) side of truck and placed as far forward on the truck hood as feasible or within the distance requirement. The label shall be positioned in the vertical plane so that it can easily be identifiable. Or the label can be positioned per the specifications below. Attach new label behind the driver's door based on the specification below.

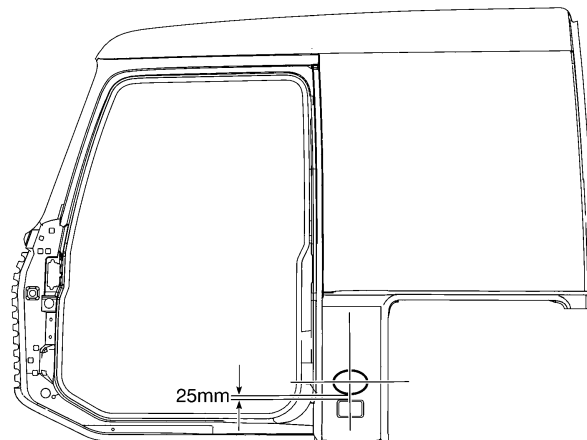

W2006784

Alternative Location

Replacement Clean Idle Labels For replacement "Clean Idle" hood labels contact Parts Interpretations by submitting an E-Service request with the following information:
1. Truck Serial number, Engine Serial number, the old "Clean Idle" serial number and PO number for purchase. 2. Also an application for engine emission or vehicle identification label form. This can be found on the Trucks Dealer Portal under, Parts, Parts Support, Forms, Volvo Forms and select Application for Engine Emission or Vehicle Identification labels. Your dealer account number will be billed \$50 US or \$75 CND against your PO number as "CARB Label."

The label will be shipped the same day Mon-Fri. There is a cut off time of 3:00 pm EST for same day shipping. If after this time, the label will be shipped the following day. (Same day shipping for single label orders only, multiple orders could take longer)

Upgrading Certification levels- This can only be done on 2007 to current emissions engines.

At this time the only option that is offered for change is converting an EPA engine to a California Certified low Nox engine.

This requires the addition of the certified clean idle hood label and 2008 and newer emission engines also require a new California Certified engine label. The current EPA engine label must be removed and destroyed.

To make this change contact Parts Interpretations through an E-Service request with the following information:

1. Truck Serial number, Engine Serial number and PO number.
2. Also an application for engine emission or vehicle identification label form. This can be found on the Trucks Dealer Portal under, Parts, Parts Support, Forms, Volvo Forms and select Application for Engine Emission or Vehicle Identification labels.

Once the changes are approved, Parts Interpretations will supply an Accessory Kit part number to be loaded in VCADS Pro. Once the Accessory Kit is performed the EECU can be programmed at no charge. There is a fee for the Accessory Kit.

Your dealer account number will be billed \$50 US or \$75 CND for the "Clean Idle" hood label and \$50 US or \$75 CND for the Engine label against your PO number as "CARB Label upgrade."

It is the dealerships responsibility to install or remove labels as required. Any removed labels must be destroyed.