

## Cylinder Head, Pressure Test D13F

### Cylinder Head, Pressure Test

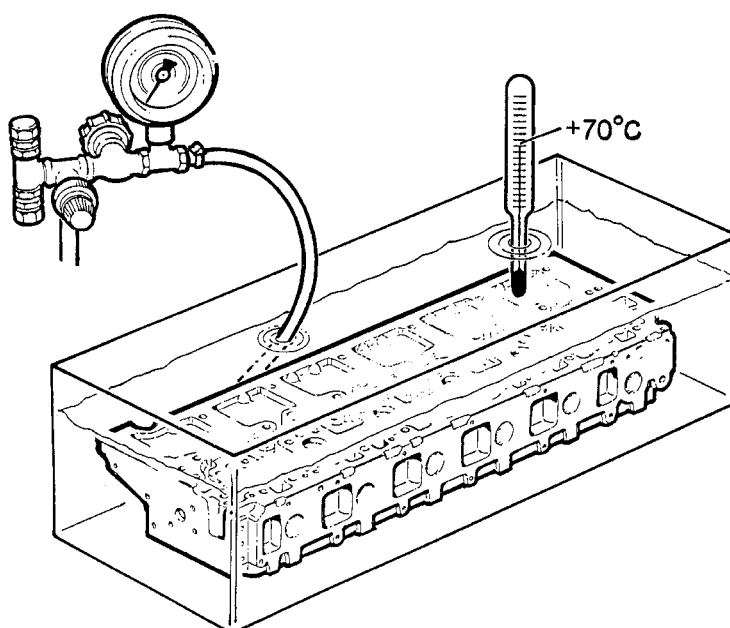

T2008809

### Contents

- "Cylinder Head, Pressure Test (First)" page 2

**Note:** Information is subject to change without notice.  
Illustrations are used for reference only and may differ slightly from the actual vehicle being serviced. However, key components addressed in this information are represented as accurately as possible.

## 2111-06-04-01 Cylinder Head, Pressure Test (First) Cylinder head removed

You must read and understand the precautions and guidelines in Service Information, group 20, "General Safety Practices, Engine" before performing this procedure. If you are not properly trained and certified in this procedure, ask your supervisor for training before you perform it.

*Special tools: 9809696, 9990106, 9990107, 9996662, 9998266*

**1**  
Remove the inlet manifold.

**2**  
Remove the exhaust manifold.

**3**  
Clean the contact surfaces on the cylinder head.

Install:

- Sealing plates 9809696 and 9998266 onto the cylinder head using cylinder head bolts and M16 nuts
- Connection disc 9990107 in the position of the thermostat housing cover
- Plug M12x1.5 in the temperature sensor hole
- Sealing plate 9990106 on the side of the cylinder head
- Lifting chain

9809696, 9990106, 9990107, 9998266

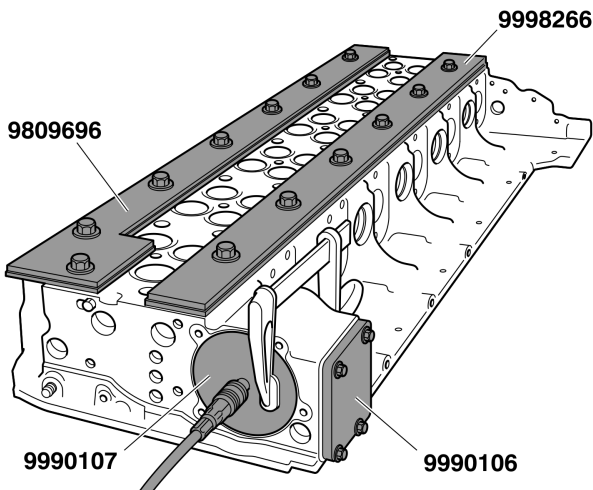

T2022359

**4**  
Connect pressure gauge 9996662. Connect the pressure gauge hose to the connection disc. Adjust the pressure to 100 kPa (14.5 psi) using the control valve. Close the stop valve for 2 minutes. The pressure should not fall.

9996662

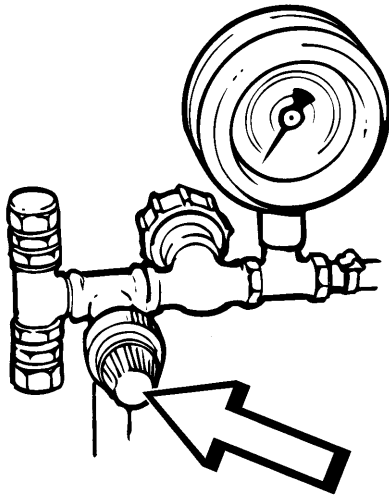

T2007039

**5**

Lower the pressure in the cylinder head by adjusting the knob on the pressure gauge control valve.

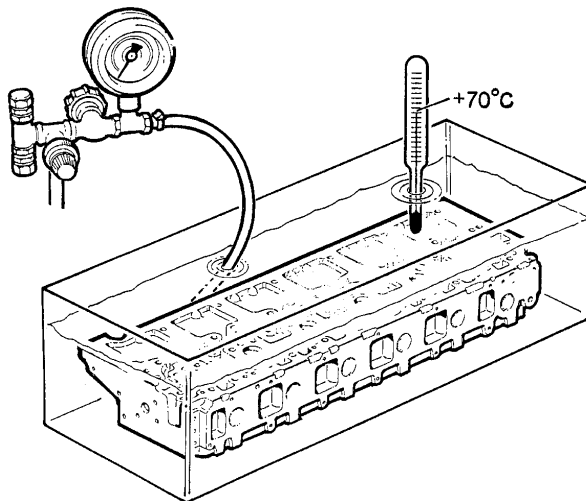

T2008809

**6**

Lower the cylinder head into a water bath at 70°C (158°F).

+70°C (158°F)

**7**

Connect an air supply to the pressure gauge. Carefully open the control valve.

**8**

Set the pressure to **50 kPa (7.25 psi)** and hold the pressure for **1 minute**.

50 kPa (7.25 psi), 1 minute

**9**

Raise the pressure to **150 kPa (21.8 psi)**. Close the stop valve and check after **2 minutes** whether the pressure has fallen or if any air bubbles are visible.

150 kPa (21.8 psi), 2 minutes

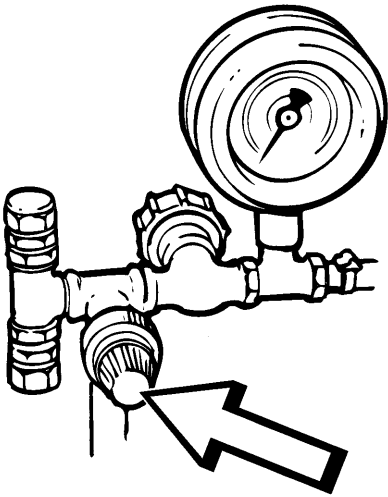

T2007039

**10**

Lower the pressure in the cylinder head by adjusting the knob on the pressure gauge control valve.

**11**

Lift the cylinder head out of the water bath.

**12**

Remove all the sealing washers.  
Using compressed air, blow the water off the cylinder head.

**Note:** Take extra care with the fuel passages.  
Make sure that no dirt enters the fuel channels, as this can cause the unit injectors to be damaged.

**13**

Clean the contact surfaces on the cylinder head and on the exhaust manifold.  
Clean all contact surfaces.

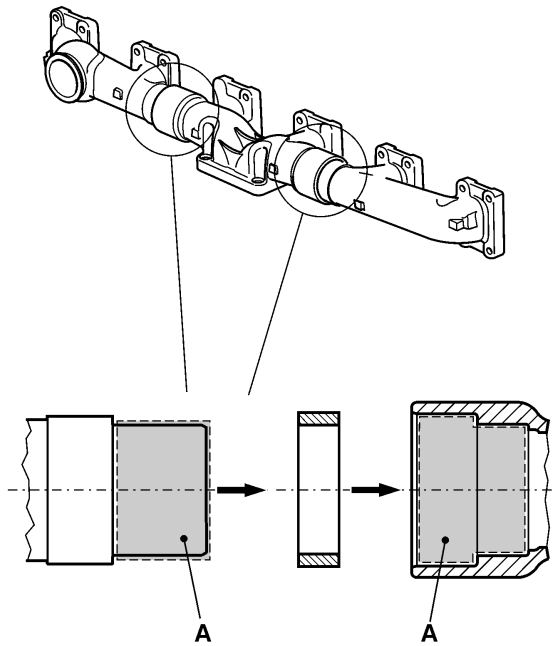

T2022111

**14**

Using new seals, install the exhaust manifold. Apply a thin layer of joint paste on the surfaces marked (A) in the illustration. Insert the seal into the female end, but do not push it all the way in. Leave a small gap between its end and the stop shoulder. Carefully fit the pipe parts together.

**Note:** Use joint paste that is approved by Volvo.

**Note:** Ensure that the sleeves fit properly in the bored out part of the exhaust manifold.

**15**

Install a new piston thermostat in the thermostat housing using new sealing.

**16**

Carefully clean the inside of the inlet manifold. Be careful not to damage the coating on the inside of the intake.

**Note:** The old seals must all be discarded.

Apply a thin layer of sealant to the sealing face for the gasket. Install the new seal.

**Note:** Ensure that the new seal fits correctly and does not stretch too much while being fitted. The inlet manifold must be fitted and torque-tightened within 20 minutes after the sealant has been applied.

Install the inlet pipe on the cylinder head and tighten to the torque given in "Specifications", refer to Group 20.

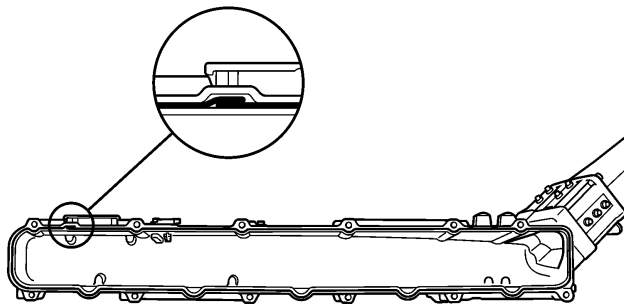

T2022144