

## Camshaft Bearing Brackets Replacement D13F

### Camshaft Bearing Brackets, Replacement

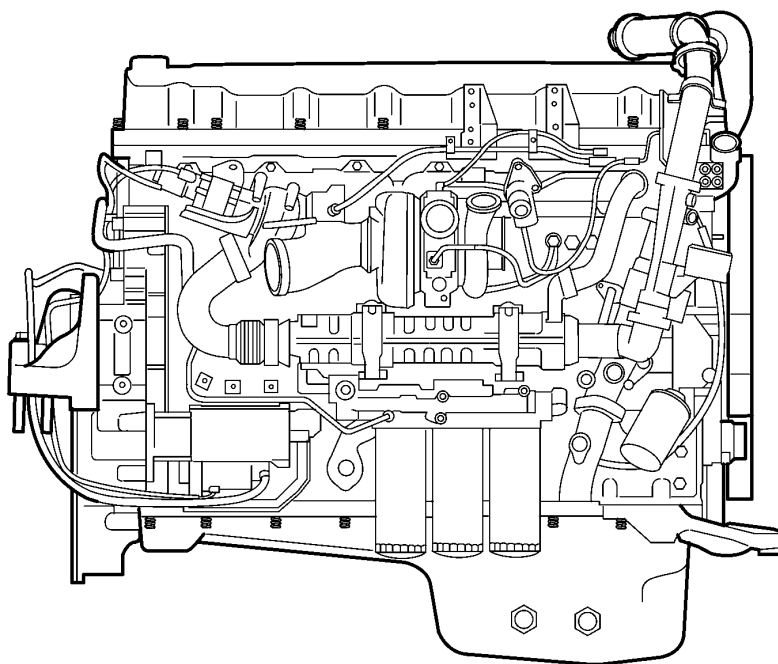

W2005779

This information covers guidelines when replacing factory or aftermarket camshaft bearing brackets (lower journals) on the Volvo D13F engine.

#### Contents

- “Camshaft Bearing Brackets, Replacement” page 2

**Note:** Information is subject to change without notice.  
Illustrations are used for reference only and may differ slightly from the actual vehicle being serviced. However, key components addressed in this information are represented as accurately as possible.

# Service Procedures

## 2119-03-03-02

### Camshaft Bearing Brackets, Replacement

Camshaft removed

You must read and understand the precautions and guidelines in Service Information, group 20, "General Safety Practices, Engine" before performing any procedure. If you are not properly trained and certified in this procedure, ask your supervisor for training before you perform it.

**Note:** Camshaft bearing journals are numbered 1–7, with matching upper and lower halves. Be sure to note and mark the corresponding journal numbers and install them in the correct sequence with matched upper and lower halves.

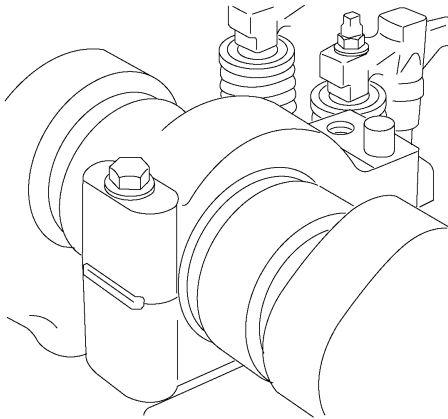

Camshaft Bearing Bracket Installed

W2005852

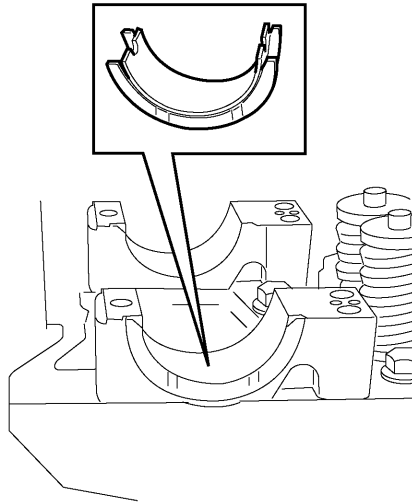

Camshaft Bearing Bracket Lower Half

W2005853

## When Replacing Factory-Installed Journals

- If a camshaft journal has seized, **DO NOT MIX** a replacement bearing bracket with the original factory-installed bearing bracket. This is because the original bearing brackets were align-bored when the engine was manufactured. **All 7 housings must be replaced.**
- When replacing a cylinder head, do not mix new bearing brackets with original bearing brackets from the old cylinder head. Use only new bearing brackets on a new cylinder head.

## When Replacing/Installing Aftermarket Journals

- If there are already replacement bearing brackets on the engine, and one bearing bracket is damaged, the brackets can be replaced one at a time. Replacement bearing brackets can be identified by the egg-shaped holes for the retaining bolts.
- If a new/replacement bearing bracket is used, torque all other bearing brackets first, to properly align the new/replacement bearing bracket.
- Mark bearing caps to indicate that aftermarket housings have been installed.

## Camshaft Inspection

- To avoid unnecessary overhauling, conduct a thorough inspection of the camshaft. Refer to Service Information, group 21.