

Date	Group	No.	Page
7.2002	831	010	1(2)

Door Panel Modification VN, VHD

Door Panel Modification

The following service procedure is for the modification process of VN and VHD series vehicles. This procedure will need to be completed when a door panel is being replaced on a door with a manual regulator. By following the attached steps, the procedure can be completed in a timely fashion, without stressing the door panel material.

Please reference TPI 831-009 "Door Panel" (7.2002), publication order number V922-831-009PB, for part numbers.

Contents:

- ["Door Panel, Modification" page 2](#)

Service Procedures

8311-05-02-04

Door Panel, Modification

1

Clean all dust or dirt from the door panel using an alcohol wipe.

2

Install the adhesive upholstery panel to the door panel assembly.

3

Flip the panel over in order to access the inside of the panel and lay it down, being careful not to scratch the material.

4

Using a 1.5" hole saw bit, drill out the area marked for a manual regulator.

NOTE: For aid in the drilling, use a block of wood to press the upholstery panel against the door panel. This will keep the fabric from tearing, yet still allowing the hole to be made.

5

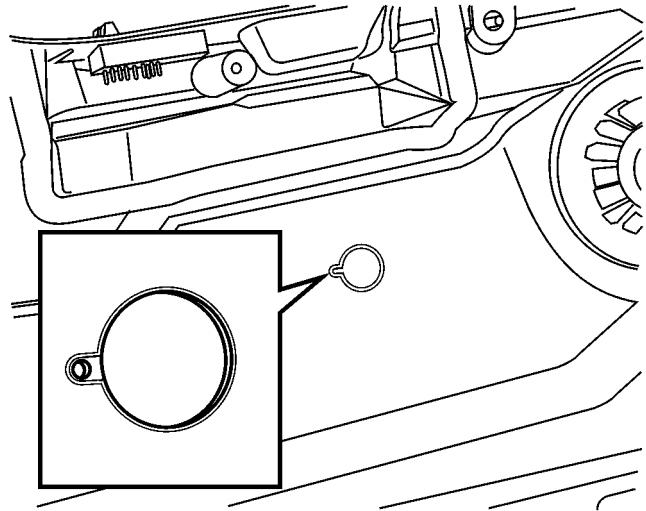

W8003061

Using a 5.5 mm drill bit, drill out the area marked for crank handle, washer line-up tab.

NOTE: For aid in the drilling, use a block of wood to press the upholstery panel against the door panel. This will keep the fabric from tearing, yet still allowing the hole to be made.