

Date	Group	No.	Page
12.96	<b>720</b>	<b>01</b>	1(1)

## New Type U-Bolts For Springs VNL, VNM

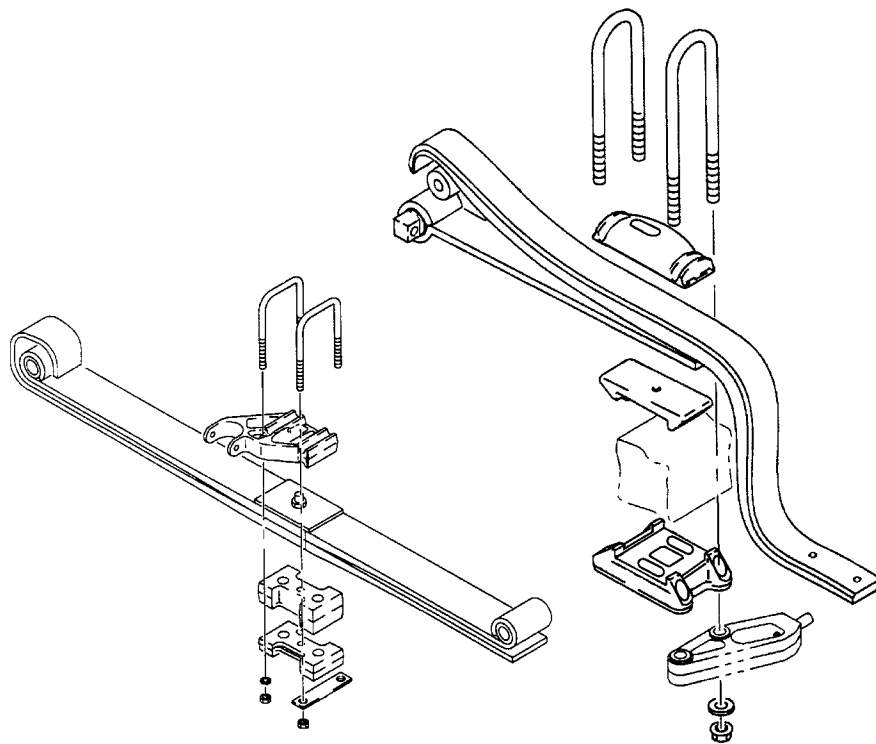

W7000532

### Spring U-Bolts, VN-Series

The spring U-bolts for the VN-series vehicles are different from the the rest of the Volvo vehicles. New U-bolt design features a coarse metric thread using a low shoulder nut.

There is a change in maintenance of the U-bolt nuts as they have to be retorqued at the first maintenance inspection, 24 000 km (15 000 miles), or earlier. Thereafter they need to be visually inspected at every maintenance inspection, just like any other U-bolts.

Front axle U-bolt nuts are tightened to a torque of 420 Nm (310 ft-lb). Rear axle U-bolt nuts are tightened to a torque of 500 Nm (370 ft-lb).